

Problem 2.1

| | A | B | C | D | E | F | G | H |
|----|--|---------|---------|---------|---------|-------|-------------------|---|
| 1 | Four Customers Connected to a 25 kVA Transformer | | | | | | | |
| 2 | | | | | | | | |
| 3 | Time | Cust #1 | Cust #2 | Cust #3 | Cust #4 | Total | Totals | |
| 4 | | kW | kW | kW | kW | | Sorted Descending | |
| 5 | 17:00 | 8.81 | 4.96 | 11.04 | 1.44 | 26.25 | 26.7 | |
| 6 | 17:15 | 2.12 | 3.16 | 7.04 | 1.62 | 13.94 | 26.25 | |
| 7 | 17:30 | 9.48 | 7.08 | 7.68 | 2.46 | 26.7 | 23.8 | |
| 8 | 17:45 | 7.16 | 5.08 | 6.08 | 0.84 | 19.16 | 20.12 | |
| 9 | 18:00 | 6.04 | 3.12 | 4.32 | 1.12 | 14.6 | 19.68 | |
| 10 | 18:15 | 9.88 | 6.56 | 5.12 | 2.24 | 23.8 | 19.24 | |
| 11 | 18:30 | 4.68 | 6.88 | 6.56 | 1.12 | 19.24 | 19.16 | |
| 12 | 18:45 | 5.12 | 3.84 | 8.48 | 2.24 | 19.68 | 18.08 | |
| 13 | 19:00 | 10.44 | 4.44 | 4.12 | 1.12 | 20.12 | 16.88 | |
| 14 | 19:15 | 3.72 | 8.52 | 3.68 | 0.96 | 16.88 | 16.26 | |
| 15 | 19:30 | 8.72 | 4.52 | 0.32 | 2.56 | 16.12 | 16.12 | |
| 16 | 19:45 | 10.84 | 2.92 | 3.04 | 1.28 | 18.08 | 15.29 | |
| 17 | 20:00 | 6.96 | 2.08 | 2.72 | 1.92 | 13.68 | 14.6 | |
| 18 | 20:15 | 6.62 | 1.48 | 3.24 | 1.12 | 12.46 | 13.94 | |
| 19 | 20:30 | 7.04 | 2.33 | 4.16 | 1.76 | 15.29 | 13.68 | |
| 20 | 20:45 | 6.69 | 1.89 | 4.96 | 2.72 | 16.26 | 12.46 | |
| 21 | 21:00 | 1.88 | 1.64 | 4.32 | 2.41 | 10.25 | 10.25 | |

Problem 2.2

Tap

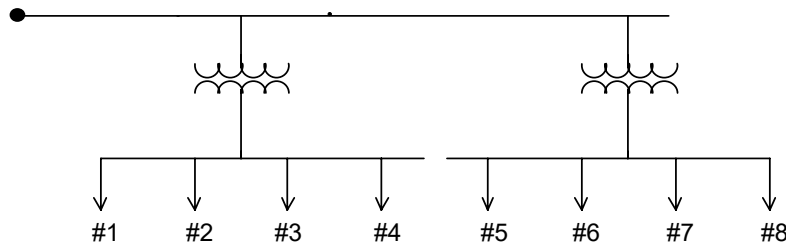

| | A | B | C | D | E | F | G |
|----|---|---|---|---|---|----------|----------|
| 1 | Problem 2.2 | | | | | | |
| 2 | | | | | | | |
| 3 | 1 For each transformer determine: | | | | | | |
| 4 | | | | | | Trf | Trf |
| 5 | | | | | | #1 | #2 |
| 6 | a. 30 minute maximum kVA demand | | | | | 105 | 128 |
| 7 | b. Non-coincident maximum kVA demand | | | | | 130.00 | 170.00 |
| 8 | c. Load factor | | | | | 0.595238 | 0.686523 |
| 9 | d. Diversity factor | | | | | 1.2381 | 1.3281 |
| 10 | e. Suggested transformer rating (50, 75, 100, 167) | | | | | 75 | 100 |
| 11 | f. Utilization factor | | | | | 1.4 | 1.2800 |
| 12 | g. Energy (kWh) during the 4 hour period | | | | | 225 | 316.3500 |
| 13 | | | | | | | |
| 14 | 2 Maximum diversified 30-minute kVA demand at the Tap | | | | | | 195 |

Problem 2.3

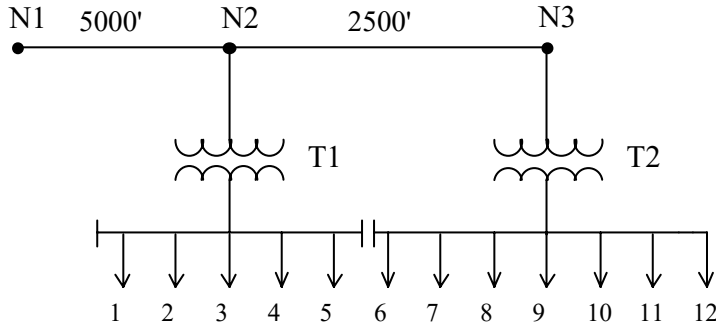

Problem 2.3.1-2.3.9 Answers for 2.3.5, 2.3.6, and 2.3.9 are kW demands

| Problem 2.3 | | | | | | | | | | | | |
|---------------------------------------|---------|---------|---------|---------|---------|---------|---------|---------|---------|----------|----------|----------|
| | Cust #1 | Cust #2 | Cust #3 | Cust #4 | Cust #5 | Cust #6 | Cust #7 | Cust #8 | Cust #9 | Cust #10 | Cust #11 | Cust #12 |
| 1. Maximum 15 minute kW demand | 3.81 | 5.81 | 4.93 | 11.26 | 6.37 | 1.56 | 1.56 | 13.48 | 1.80 | 8.97 | 8.99 | 12.23 |
| 2. Average 15 minute kW demand | 2.45 | 1.61 | 3.59 | 9.26 | 1.56 | 0.82 | 5.15 | 0.69 | 3.34 | 5.42 | 9.06 | 2.05 |
| 3. Total KWH usage in the time period | 10.42 | 6.85 | 15.26 | 39.36 | 6.65 | 3.47 | 21.89 | 2.92 | 14.20 | 23.05 | 38.49 | 8.71 |
| 4. Load factor | 0.6437 | 0.2774 | 0.7284 | 0.8225 | 0.2456 | 0.5230 | 3.3017 | 0.0510 | 1.8565 | 0.6045 | 1.0073 | 0.1676 |
| | Trf #1 | Trf #2 | | | | | | | | | | |
| 5. Maximum diversified demand | 22.71 | 41.56 | | | | | | | | | | |
| 6. Maximum non-coincident demand | 32.18 | 48.59 | | | | | | | | | | |
| 7. Utilization factor | 0.9084 | 1.1083 | | | | | | | | | | |
| 8. Diversity factor | 1.4170 | 1.1692 | | | | | | | | | | |
| 9. Maximum Diversified demand at N1 | 57.89 | | | | | | | | | | | |

Problem 2.3.j

$$V_{N1} := 2500 \cdot e^{j \cdot 0 \text{deg}} \quad \text{pf} := .95 \quad \text{kVA}_{T1} := 25 \quad \text{kVA}_{T2} := 37.5 \quad \text{kV}_{hi} := 2.4 \quad V_{low} := 240$$

$$z_{line} := 0.306 + 0.6272j \quad z_{pu_{T1}} := 0.018 \cdot e^{j \cdot 40 \text{deg}} \quad z_{pu_{T2}} := 0.02 \cdot e^{j \cdot 50 \text{deg}}$$

$$D_{N1N2} := 5000 \quad D_{N2N3} := 2500$$

$$Z_{base_{T1}} := \frac{\text{kV}_{hi}^2 \cdot 1000}{\text{kVA}_{T1}} \quad Z_{base_{T1}} = 230.4000$$

$$Z_{T1} := z_{pu_{T1}} \cdot Z_{base_{T1}} \quad Z_{T1} = 3.1769 + 2.6658j$$

$$Z_{base_{T2}} := \frac{\text{kV}_{hi}^2 \cdot 1000}{\text{kVA}_{T2}} \quad Z_{base_{T2}} = 153.6000$$

$$Z_{T2} := z_{pu_{T2}} \cdot Z_{base_{T2}} \quad Z_{T2} = 1.9746 + 2.3533j$$

$$z_{N1N2} := z_{line} \cdot \frac{D_{N1N2}}{5280} \quad z_{N1N2} = 0.2898 + 0.5939j$$

$$z_{N2N3} := z_{line} \cdot \frac{D_{N2N3}}{5280} \quad z_{N2N3} = 0.1449 + 0.2970j$$

Note: The voltage drops will be computed for a "worst case" situation. For each segment or transformer the maximum kVA demand on that segment or transformer will be used to compute the voltage drop to the remote end. This remote end voltage will then be assumed to be the voltage at that node when the maximum diversified demand downstream occurs.

$$kVADemand_{N1} := \frac{57.89}{pf} \cdot e^{j \cdot \text{acos}(pf)} \quad |kVADemand_{N1}| = 60.9368 \quad \frac{\arg(kVADemand_{N1})}{\text{deg}} = 18.1949$$

$$I_{N1N2} := \frac{\overline{kVADemand_{N1}}}{\frac{V_{N1}}{1000}} \quad |I_{N1N2}| = 24.3747 \quad \frac{\arg(I_{N1N2})}{\text{deg}} = -18.1949$$

$$V_{N2} := V_{N1} - Z_{N1N2} \cdot I_{N1N2} \quad |V_{N2}| = 2488.7963 \quad \frac{\arg(V_{N2})}{\text{deg}} = -0.2658$$

$$kVADemand_{T1} := \frac{22.71}{pf} \cdot e^{j \cdot \text{acos}(pf)} \quad |kVADemand_{T1}| = 23.9053 \quad \frac{\arg(kVADemand_{T1})}{\text{deg}} = 18.1949$$

$$I_{T1} := \frac{\overline{kVADemand_{T1}}}{\frac{V_{N2}}{1000}} \quad |I_{T1}| = 9.6052 \quad \frac{\arg(I_{T1})}{\text{deg}} = -17.9290$$

$$V_{T1} := V_{N2} - I_{T1} \cdot Z_{T1} \quad |V_{T1}| = 2451.9975 \quad \frac{\arg(V_{T1})}{\text{deg}} = -0.6196$$

$$V_{\text{low}T1} := V_{T1} \cdot \left(\frac{V_{\text{low}}}{kV_{hi} \cdot 1000} \right) \quad |V_{\text{low}T1}| = 245.1998$$

$$kVADemand_{N2} := \frac{41.56}{pf} \cdot e^{j \cdot \text{acos}(pf)} \quad |kVADemand_{N2}| = 43.7474 \quad \frac{\arg(kVADemand_{N2})}{\text{deg}} = 18.1949$$

$$I_{N2N3} := \frac{\overline{kVADemand_{N2}}}{\frac{V_{N1}}{1000}} \quad |I_{N2N3}| = 17.4989 \quad \frac{\arg(I_{N2N3})}{\text{deg}} = -18.1949$$

$$V_{N3} := V_{N2} - Z_{N2N3} \cdot I_{N2N3} \quad |V_{N3}| = 2484.7879 \quad \frac{\arg(V_{N3})}{\text{deg}} = -0.3619$$

$$V_{T2} := V_{N3} - I_{N2N3} \cdot Z_{T2} \quad |V_{T2}| = 2439.4506 \quad \frac{\arg(V_{T2})}{\text{deg}} = -1.0341$$

$$V_{\text{low}T2} := V_{T2} \cdot \left(\frac{V_{\text{low}}}{kV_{hi} \cdot 1000} \right) \quad |V_{\text{low}T2}| = 243.9451$$

Problem 2.4

$$V_{N1} := 2500 \cdot e^{j \cdot 0\text{deg}} \quad pf := .95 \quad kVA_{T1} := 25 \quad kVA_{T2} := 37.5 \quad kV_{hi} := 2.4 \quad V_{\text{low}} := 240$$

$$z_{\text{line}} := 0.306 + 0.6272j \quad z_{pu_{T1}} := 0.018 \cdot e^{j \cdot 40\text{deg}} \quad z_{pu_{T2}} := 0.02 \cdot e^{j \cdot 50\text{deg}}$$

$$D_{N1N2} := 5000 \quad D_{N2N3} := 2500$$

$$Z_{baseT1} := \frac{kV_{hi}^2 \cdot 1000}{kVA_{T1}} \quad Z_{baseT1} = 230.4000$$

$$Z_{T1} := zpu_{T1} \cdot Z_{baseT1} \quad Z_{T1} = 3.1769 + 2.6658j$$

$$Z_{baseT2} := \frac{kV_{hi}^2 \cdot 1000}{kVA_{T2}} \quad Z_{baseT2} = 153.6000$$

$$Z_{T2} := zpu_{T2} \cdot Z_{baseT2} \quad Z_{T2} = 1.9746 + 2.3533j$$

$$z_{N1N2} := z_{line} \cdot \frac{D_{N1N2}}{5280} \quad z_{N1N2} = 0.2898 + 0.5939j$$

$$z_{N2N3} := z_{line} \cdot \frac{D_{N2N3}}{5280} \quad z_{N2N3} = 0.1449 + 0.2970j$$

$$kW_{Demand_{N1}} := 72.43 \quad pf := 0.95$$

$$kVA_{T1} := 25 \quad kVA_{T2} := 37.5$$

$$kVADemand_{N1} := \frac{kW_{Demand_{N1}}}{pf} \cdot e^{j \cdot \arccos(pf)} \quad |kVADemand_{N1}| = 76.2421 \quad \frac{\arg(kVADemand_{N1})}{deg} = 18.1949$$

$$kVA_{total} := kVA_{T1} + kVA_{T2}$$

$$AF := \frac{kW_{Demand_{N1}}}{kVA_{total}}$$

$$AF = 1.1589$$

$$kW_{Demand_{T1}} := AF \cdot kVA_{T1} \quad kW_{Demand_{T1}} = 28.9720$$

$$kW_{Demand_{T2}} := AF \cdot kVA_{T2} \quad kW_{Demand_{T2}} = 43.4580$$

$$kVADemand_{T1} := \frac{kW_{Demand_{T1}}}{pf} \cdot e^{j \cdot (\arccos(pf))} \quad |kVADemand_{T1}| = 30.4968 \quad \frac{\arg(kVADemand_{T1})}{deg} = 18.1949$$

$$kVADemand_{T2} := \frac{kW_{Demand_{T2}}}{pf} \cdot e^{j \cdot (\arccos(pf))} \quad |kVADemand_{T2}| = 45.7453 \quad \frac{\arg(kVADemand_{T2})}{deg} = 18.1949$$

Note: For all segment and transformer currents, for the constant current model the allocated kVA will be used along with the Node N1 voltage to compute the currents.

$$I_{N1N2} := \frac{\overline{kVADemand_{N1}}}{\frac{V_{N1}}{1000}} \quad |I_{N1N2}| = 30.4968 \quad \frac{\arg(I_{N1N2})}{deg} = -18.1949$$

$$V_{N2} := V_{N1} - Z_{N1N2} \cdot I_{N1N2} \quad |V_{N2}| = 2485.9908 \quad \frac{\arg(V_{N2})}{\text{deg}} = -0.3330$$

$$I_{T1} := \frac{\overline{\text{kVADemand}_{T1}}}{\frac{V_{N1}}{1000}} \quad |I_{T1}| = 12.1987 \quad \frac{\arg(I_{T1})}{\text{deg}} = -18.1949$$

$$V_{T1} := V_{N2} - I_{T1} \cdot Z_{T1} \quad |V_{T1}| = 2439.2044 \quad \frac{\arg(V_{T1})}{\text{deg}} = -0.7808$$

$$V_{\text{low}T1} := V_{T1} \cdot \left(\frac{V_{\text{low}}}{\text{kV}_{\text{hi}} \cdot 1000} \right) \quad |V_{\text{low}T1}| = 243.9204 \quad \frac{\arg(V_{\text{low}T1})}{\text{deg}} = -0.7808$$

$$\text{kVADemand}_{N2} := \text{kVADemand}_{T2} \quad |\text{kVADemand}_{N2}| = 45.7453 \quad \frac{\arg(\text{kVADemand}_{N2})}{\text{deg}} = 18.1949$$

$$I_{N2N3} := \frac{\overline{\text{kVADemand}_{N2}}}{\frac{V_{N1}}{1000}} \quad |I_{N2N3}| = 18.2981 \quad \frac{\arg(I_{N2N3})}{\text{deg}} = -18.1949$$

$$V_{N3} := V_{N2} - Z_{N2N3} \cdot I_{N2N3} \quad |V_{N3}| = 2481.8046 \quad \frac{\arg(V_{N3})}{\text{deg}} = -0.4336$$

$$V_{T2} := V_{N3} - I_{N2N3} \cdot Z_{T2} \quad |V_{T2}| = 2434.4435 \quad \frac{\arg(V_{T2})}{\text{deg}} = -1.1394$$

$$V_{\text{low}T2} := V_{T2} \cdot \left(\frac{V_{\text{low}}}{\text{kV}_{\text{hi}} \cdot 1000} \right) \quad |V_{\text{low}T2}| = 243.4443$$

Problem

2.5

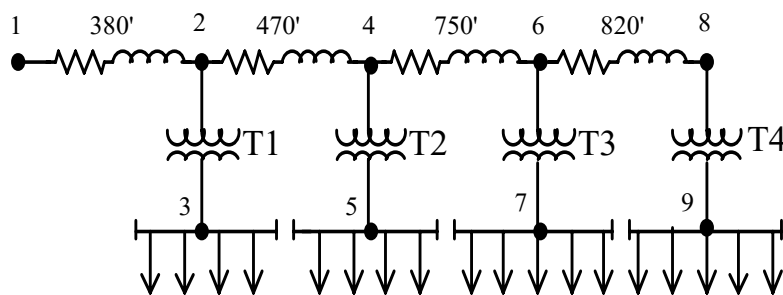

$$\text{CustMaxDem} := 15.5 + 7.5j$$

$$V_{N1} := 2600 \cdot e^{j \cdot 0 \text{deg}} \quad \text{pf} := .95$$

$$z_{\text{line}} := 0.4421 + 0.3213j$$

$$\text{kVA}_{T1} := 37.5$$

$$\text{kVA}_{T2} := \text{kVA}_{T1}$$

$$\text{kVA}_{T3} := 50$$

$$\text{kVA}_{T4} := \text{kVA}_{T3}$$

$$z_{\text{pu}T1} := 0.01 + 0.03j$$

$$z_{\text{pu}T2} := z_{\text{pu}T1}$$

$$z_{\text{pu}T3} := 0.015 + 0.035j$$

$$z_{\text{pu}T4} := z_{\text{pu}T3}$$

$$\text{kV}_{\text{hi}} := 2.4$$

$$V_{\text{low}} := 240$$

$$\text{DF}_4 := 2.1$$

$$\text{DF}_5 := 2.2$$

$$\text{DF}_{10} := 2.65$$

$$\text{DF}_{14} := 2.78$$

$$\text{DF}_{18} := 2.86$$

Problem 2.5.a

$$\text{kVADemand}_{T1} := \frac{4 \cdot \text{CustMaxDem}}{\text{DF}_4}$$

$$\text{kVADemand}_{T1} = 29.5238 + 14.2857j$$

$$\text{kVADemand}_{T2} := \frac{4 \cdot \text{CustMaxDem}}{\text{DF}_4}$$

$$\text{kVADemand}_{T2} = 29.5238 + 14.2857j$$

$$\text{kVADemand}_{T3} := \frac{5 \cdot \text{CustMaxDem}}{\text{DF}_5}$$

$$\text{kVADemand}_{T3} = 35.2273 + 17.0455j$$

$$\text{kVADemand}_{T4} := \frac{5 \cdot \text{CustMaxDem}}{\text{DF}_5}$$

$$\text{kVADemand}_{T4} = 35.2273 + 17.0455j$$

Problem 2.5.b

$$\text{kVADemand}_{N1N2} := \frac{18 \cdot \text{CustMaxDem}}{\text{DF}_{18}}$$

$$\text{kVADemand}_{N1N2} = 97.5524 + 47.2028j$$

$$\text{kVADemand}_{N2N4} := \frac{14 \cdot \text{CustMaxDem}}{\text{DF}_{14}}$$

$$\text{kVADemand}_{N2N4} = 78.0576 + 37.7698j$$

$$\text{kVADemand}_{N4N6} := \frac{10 \cdot \text{CustMaxDem}}{\text{DF}_{10}}$$

$$\text{kVADemand}_{N4N6} = 58.4906 + 28.3019j$$

$$\text{kVADemand}_{N6N8} := \frac{5 \cdot \text{CustMaxDem}}{\text{DF}_5}$$

$$\text{kVADemand}_{N6N8} = 35.2273 + 17.0455j$$

Problem 2.5.c

$$D_{N1N2} := 380$$

$$D_{N2N4} := 470$$

$$D_{N4N6} := 750$$

$$D_{N6N8} := 820$$

$$z_{N1N2} := z_{\text{line}} \cdot \frac{D_{N1N2}}{1000}$$

$$z_{N1N2} = 0.1680 + 0.1221j$$

$$z_{N2N4} := z_{\text{line}} \cdot \frac{D_{N2N4}}{1000}$$

$$z_{N2N4} = 0.2078 + 0.1510j$$

$$z_{N4N6} := z_{\text{line}} \cdot \frac{D_{N4N6}}{1000}$$

$$z_{N4N6} = 0.3316 + 0.2410j$$

$$z_{N6N8} := z_{\text{line}} \cdot \frac{D_{N6N8}}{1000}$$

$$z_{N6N8} = 0.3625 + 0.2635j$$

$$Z_{\text{base}T1} := \frac{\text{kV}_{\text{hi}}^2 \cdot 1000}{\text{kVA}_{T1}}$$

$$Z_{\text{base}T1} = 153.6000$$

$$Z_{\text{base}T3} := \frac{\text{kV}_{\text{hi}}^2 \cdot 1000}{\text{kVA}_{T3}}$$

$$Z_{\text{base}T3} = 115.2000$$

$$Z_{T1} := z_{\text{pu}T1} \cdot Z_{\text{base}T1}$$

$$Z_{T1} = 1.5360 + 4.6080j$$

$$Z_{T3} := z_{\text{pu}T3} \cdot Z_{\text{base}T3}$$

$$Z_{T3} = 1.7280 + 4.0320j$$

$$Z_{\text{base}T2} := \frac{\text{kV}_{\text{hi}}^2 \cdot 1000}{\text{kVA}_{T2}}$$

$$Z_{\text{base}T2} = 153.6000$$

$$Z_{\text{base}T4} := \frac{\text{kV}_{\text{hi}}^2 \cdot 1000}{\text{kVA}_{T4}}$$

$$Z_{\text{base}T4} = 115.2000$$

$$Z_{T2} := z_{\text{pu}T2} \cdot Z_{\text{base}T2}$$

$$Z_{T2} = 1.5360 + 4.6080j$$

$$Z_{T4} := z_{\text{pu}T4} \cdot Z_{\text{base}T4}$$

$$Z_{T4} = 1.7280 + 4.0320j$$

$$I_{N1N2} := \frac{\text{kVADemand}_{N1N2}}{\frac{V_{N1}}{1000}}$$

$$|I_{N1N2}| = 41.6817$$

$$\frac{\arg(I_{N1N2})}{\text{deg}} = -25.8210$$

| | | |
|---|------------------------|--|
| $V_{N2} := V_{N1} - Z_{N1N2} \cdot I_{N1N2}$ | $ V_{N2} = 2591.4805$ | $\frac{\arg(V_{N2})}{\text{deg}} = -0.0338$ |
| $I_{T1} := \frac{\overline{\text{kVADemand}_{T1}}}{\frac{V_{N2}}{1000}}$ | $ I_{T1} = 12.6563$ | $\frac{\arg(I_{T1})}{\text{deg}} = -25.7871$ |
| $V_{T1} := V_{N2} - I_{T1} \cdot Z_{T1}$ | $ V_{T1} = 2549.0127$ | $\frac{\arg(V_{T1})}{\text{deg}} = -1.0247$ |
| $V_{N3} := V_{T1} \cdot \left(\frac{V_{\text{low}}}{\text{kV}_{\text{hi}} \cdot 1000} \right)$ | $ V_{N3} = 254.9013$ | $\frac{\arg(V_{N3})}{\text{deg}} = -1.0247$ |
| $I_{N2N4} := \frac{\overline{\text{kVADemand}_{N2N4}}}{\frac{V_{N2}}{1000}}$ | $ I_{N2N4} = 33.4617$ | $\frac{\arg(I_{N2N4})}{\text{deg}} = -25.8548$ |
| $V_{N4} := V_{N2} - Z_{N2N4} \cdot I_{N2N4}$ | $ V_{N4} = 2583.0213$ | $\frac{\arg(V_{N4})}{\text{deg}} = -0.0676$ |
| $I_{T2} := \frac{\overline{\text{kVADemand}_{T2}}}{\frac{V_{N4}}{1000}}$ | $ I_{T2} = 12.6977$ | $\frac{\arg(I_{T2})}{\text{deg}} = -25.7534$ |
| $V_{T2} := V_{N4} - I_{T2} \cdot Z_{T2}$ | $ V_{T2} = 2540.4700$ | $\frac{\arg(V_{T2})}{\text{deg}} = -1.0662$ |
| $V_{N5} := V_{T2} \cdot \left(\frac{V_{\text{low}}}{\text{kV}_{\text{hi}} \cdot 1000} \right)$ | $ V_{N5} = 254.0470$ | $\frac{\arg(V_{N5})}{\text{deg}} = -1.0662$ |
| $I_{N4N6} := \frac{\overline{\text{kVADemand}_{N4N6}}}{\frac{V_{N4}}{1000}}$ | $ I_{N4N6} = 25.1558$ | $\frac{\arg(I_{N4N6})}{\text{deg}} = -25.8886$ |
| $V_{N6} := V_{N4} - Z_{N4N6} \cdot I_{N4N6}$ | $ V_{N6} = 2572.8734$ | $\frac{\arg(V_{N6})}{\text{deg}} = -0.1082$ |
| $I_{T3} := \frac{\overline{\text{kVADemand}_{T3}}}{\frac{V_{N6}}{1000}}$ | $ I_{T3} = 15.2104$ | $\frac{\arg(I_{T3})}{\text{deg}} = -25.7128$ |
| $V_{T3} := V_{N6} - I_{T3} \cdot Z_{T3}$ | $ V_{T3} = 2523.0500$ | $\frac{\arg(V_{T3})}{\text{deg}} = -1.1062$ |