

PROBLEM 1.1

KNOWN: Thermal conductivity, thickness and temperature difference across a sheet of rigid extruded insulation.

FIND: (a) The heat flux through a $2\text{ m} \times 2\text{ m}$ sheet of the insulation, and (b) The heat rate through the sheet.

SCHEMATIC:

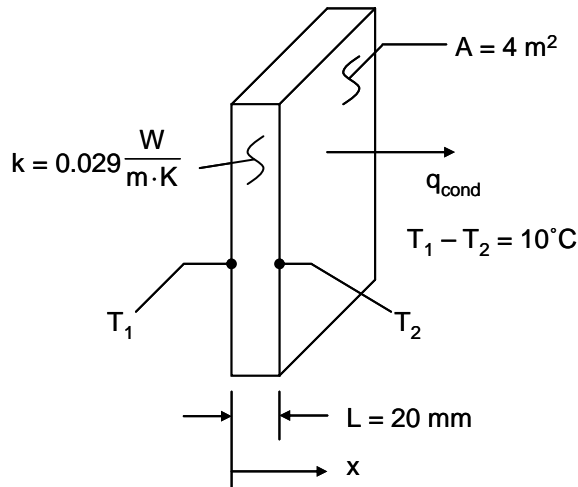

ASSUMPTIONS: (1) One-dimensional conduction in the x-direction, (2) Steady-state conditions, (3) Constant properties.

ANALYSIS: From Equation 1.2 the heat flux is

$$q_x'' = -k \frac{dT}{dx} = k \frac{T_1 - T_2}{L}$$

Solving,

$$q_x'' = 0.029 \frac{\text{W}}{\text{m} \cdot \text{K}} \times \frac{10 \text{ K}}{0.02 \text{ m}}$$

$$q_x'' = 14.5 \frac{\text{W}}{\text{m}^2} \quad <$$

The heat rate is

$$q_x = q_x'' \cdot A = 14.5 \frac{\text{W}}{\text{m}^2} \times 4 \text{ m}^2 = 58 \text{ W} \quad <$$

COMMENTS: (1) Be sure to keep in mind the important distinction between the heat flux (W/m^2) and the heat rate (W). (2) The direction of heat flow is from hot to cold. (3) Note that a temperature *difference* may be expressed in kelvins or degrees Celsius.

PROBLEM 1.2

KNOWN: Thickness and thermal conductivity of a wall. Heat flux applied to one face and temperatures of both surfaces.

FIND: Whether steady-state conditions exist.

SCHEMATIC:

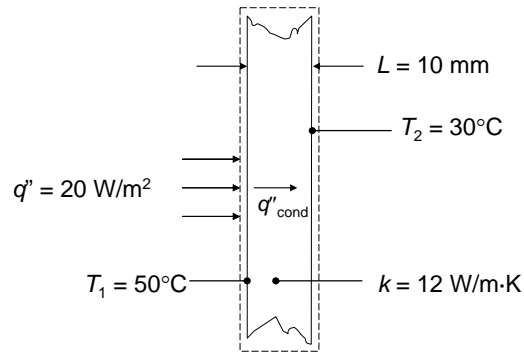

ASSUMPTIONS: (1) One-dimensional conduction, (2) Constant properties, (3) No internal energy generation.

ANALYSIS: Under steady-state conditions an energy balance on the control volume shown is

$$q''_{\text{in}} = q''_{\text{out}} = q''_{\text{cond}} = k(T_1 - T_2)/L = 12 \text{ W/m}\cdot\text{K}(50^\circ\text{C} - 30^\circ\text{C})/0.01 \text{ m} = 24,000 \text{ W/m}^2$$

Since the heat flux in at the left face is only 20 W/m^2 , the conditions are not steady state. <

COMMENTS: If the same heat flux is maintained until steady-state conditions are reached, the steady-state temperature difference across the wall will be

$$\Delta T = q''L/k = 20 \text{ W/m}^2 \times 0.01 \text{ m}/12 \text{ W/m}\cdot\text{K} = 0.0167 \text{ K}$$

which is much smaller than the specified temperature difference of 20°C .

PROBLEM 1.3

KNOWN: Inner surface temperature and thermal conductivity of a concrete wall.

FIND: Heat loss by conduction through the wall as a function of outer surface temperatures ranging from -15 to 38°C .

SCHEMATIC:

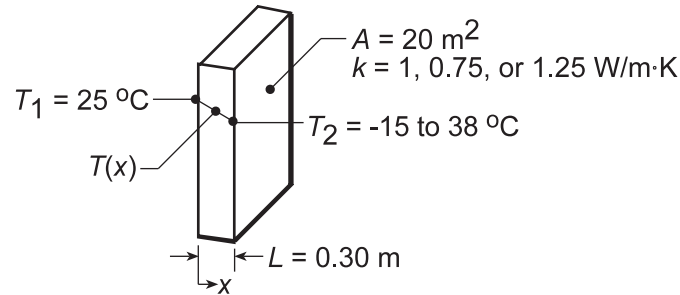

ASSUMPTIONS: (1) One-dimensional conduction in the x -direction, (2) Steady-state conditions, (3) Constant properties.

ANALYSIS: From Fourier's law, if q_x'' and k are each constant it is evident that the gradient, $dT/dx = -q_x''/k$, is a constant, and hence the temperature distribution is linear. The heat flux must be constant under one-dimensional, steady-state conditions; and k is approximately constant if it depends only weakly on temperature. The heat flux and heat rate when the outside wall temperature is $T_2 = -15^\circ\text{C}$ are

$$q_x'' = -k \frac{dT}{dx} = k \frac{T_1 - T_2}{L} = 1 \text{ W/m} \cdot \text{K} \frac{25^\circ\text{C} - (-15^\circ\text{C})}{0.30 \text{ m}} = 133.3 \text{ W/m}^2. \quad (1)$$

$$q_x = q_x'' \times A = 133.3 \text{ W/m}^2 \times 20 \text{ m}^2 = 2667 \text{ W}. \quad (2) <$$

Combining Eqs. (1) and (2), the heat rate q_x can be determined for the range of outer surface temperature, $-15 \leq T_2 \leq 38^\circ\text{C}$, with different wall thermal conductivities, k .

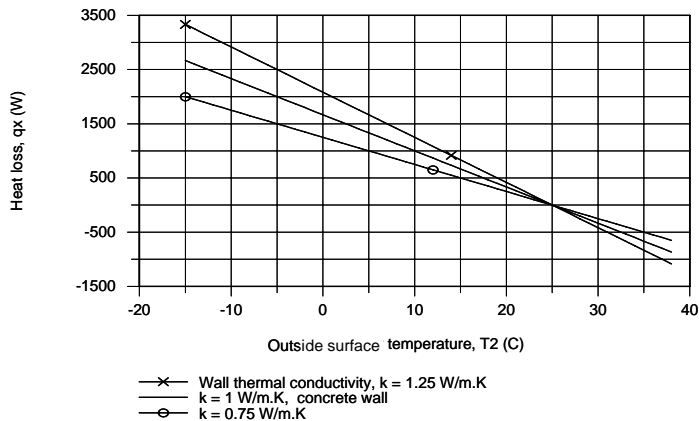

For the concrete wall, $k = 1 \text{ W/m}\cdot\text{K}$, the heat loss varies linearly from $+2667 \text{ W}$ to -867 W and is zero when the inside and outer surface temperatures are the same. The magnitude of the heat rate increases with increasing thermal conductivity.

COMMENTS: Without steady-state conditions and constant k , the temperature distribution in a plane wall would not be linear.

PROBLEM 1.4

KNOWN: Dimensions, thermal conductivity and surface temperatures of a concrete slab. Efficiency of gas furnace and cost of natural gas.

FIND: Daily cost of heat loss.

SCHEMATIC:

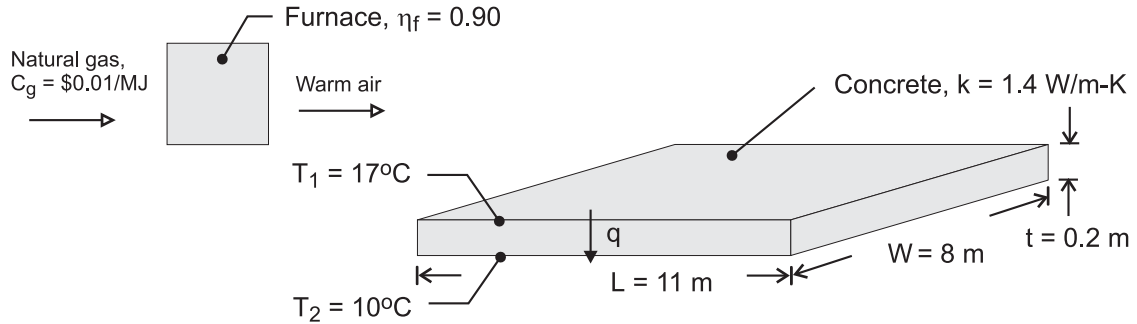

ASSUMPTIONS: (1) Steady state, (2) One-dimensional conduction, (3) Constant properties.

ANALYSIS: The rate of heat loss by conduction through the slab is

$$q = k(LW) \frac{T_1 - T_2}{t} = 1.4 \text{ W/m} \cdot \text{K} (11 \text{ m} \times 8 \text{ m}) \frac{7^\circ\text{C}}{0.20 \text{ m}} = 4312 \text{ W} \quad <$$

The daily cost of natural gas that must be combusted to compensate for the heat loss is

$$C_d = \frac{q C_g}{\eta_f} (\Delta t) = \frac{4312 \text{ W} \times \$0.02 / \text{MJ}}{0.9 \times 10^6 \text{ J/MJ}} (24 \text{ h/d} \times 3600 \text{ s/h}) = \$8.28 / \text{d} \quad <$$

COMMENTS: The loss could be reduced by installing a floor covering with a layer of insulation between it and the concrete.

PROBLEM 1.5

KNOWN: Thermal conductivity and thickness of a wall. Heat flux through wall. Steady-state conditions.

FIND: Value of temperature gradient in K/m and in °C/m.

SCHEMATIC:

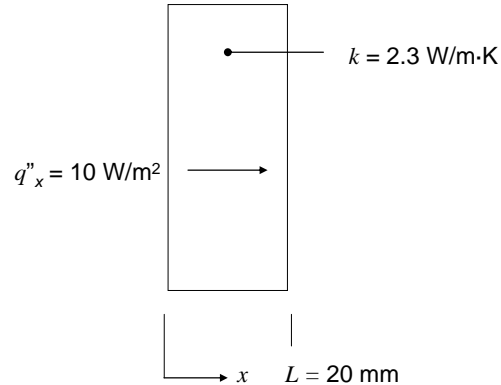

ASSUMPTIONS: (1) One-dimensional conduction, (2) Constant properties.

ANALYSIS: Under steady-state conditions,

$$\frac{dT}{dx} = -\frac{q''_x}{k} = -\frac{10 \text{ W/m}^2}{2.3 \text{ W/m}\cdot\text{K}} = -4.35 \text{ K/m} = -4.35 \text{ }^\circ\text{C/m} \quad <$$

Since the K units here represent a temperature *difference*, and since the temperature difference is the same in K and °C units, the temperature gradient value is the same in either units.

COMMENTS: A negative value of temperature gradient means that temperature is decreasing with increasing x , corresponding to a positive heat flux in the x -direction.

PROBLEM 1.6

KNOWN: Heat flux and surface temperatures associated with a wood slab of prescribed thickness.

FIND: Thermal conductivity, k , of the wood.

SCHEMATIC:

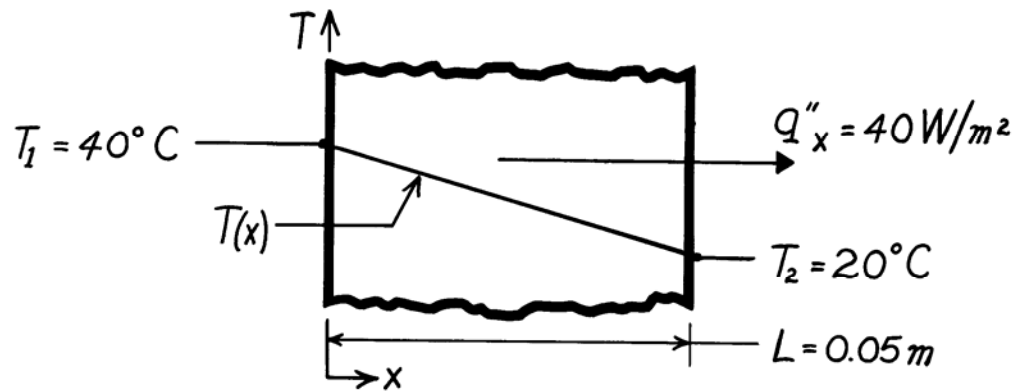

ASSUMPTIONS: (1) One-dimensional conduction in the x -direction, (2) Steady-state conditions, (3) Constant properties.

ANALYSIS: Subject to the foregoing assumptions, the thermal conductivity may be determined from Fourier's law, Eq. 1.2. Rearranging,

$$k = q''_x \frac{L}{T_1 - T_2} = 40 \frac{\text{W}}{\text{m}^2} \frac{0.05 \text{ m}}{(40 - 20)^\circ \text{C}}$$

$$k = 0.10 \text{ W/m} \cdot \text{K}$$

<

COMMENTS: Note that the $^\circ\text{C}$ or K temperature units may be used interchangeably when evaluating a temperature difference.

PROBLEM 1.7

KNOWN: Inner and outer surface temperatures of a glass window of prescribed dimensions.

FIND: Heat loss through window.

SCHEMATIC:

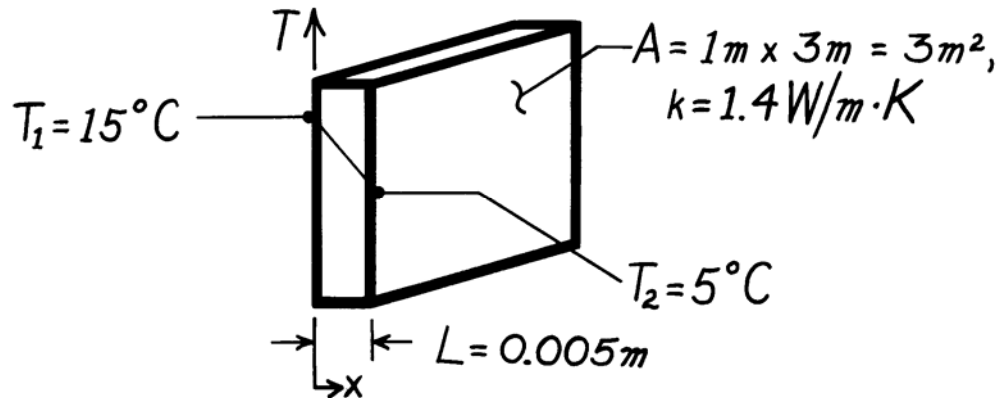

ASSUMPTIONS: (1) One-dimensional conduction in the x -direction, (2) Steady-state conditions, (3) Constant properties.

ANALYSIS: Subject to the foregoing conditions the heat flux may be computed from Fourier's law, Eq. 1.2.

$$q_x'' = k \frac{T_1 - T_2}{L}$$
$$q_x'' = 1.4 \frac{\text{W}}{\text{m}\cdot\text{K}} \frac{(15-5)^\circ\text{C}}{0.005\text{m}}$$
$$q_x'' = 2800 \text{ W/m}^2.$$

Since the heat flux is uniform over the surface, the heat loss (rate) is

$$q = q_x'' \times A$$
$$q = 2800 \text{ W/m}^2 \times 3\text{m}^2$$
$$q = 8400 \text{ W.}$$

COMMENTS: A linear temperature distribution exists in the glass for the prescribed conditions.

PROBLEM 1.8

KNOWN: Net power output, average compressor and turbine temperatures, shaft dimensions and thermal conductivity.

FIND: (a) Comparison of the conduction rate through the shaft to the predicted net power output of the device, (b) Plot of the ratio of the shaft conduction heat rate to the anticipated net power output of the device over the range $0.005 \text{ m} \leq L \leq 1 \text{ m}$ and feasibility of a $L = 0.005 \text{ m}$ device.

SCHEMATIC:

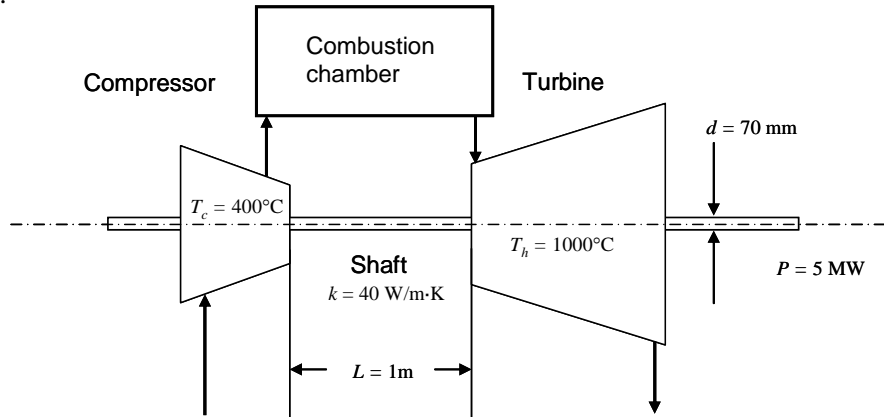

ASSUMPTIONS: (1) Steady-state conditions, (2) Constant properties, (3) Net power output is proportional to the volume of the gas turbine.

PROPERTIES: Shaft (given): $k = 40 \text{ W/m}\cdot\text{K}$.

ANALYSIS: (a) The conduction through the shaft may be evaluated using Fourier's law, yielding

$$q = q'' A_c = \frac{k(T_h - T_c)}{L} (\pi d^2 / 4) = \frac{40 \text{ W/m}\cdot\text{K} (1000 - 400)^\circ\text{C}}{1 \text{ m}} (\pi (70 \times 10^{-3} \text{ m})^2 / 4) = 92.4 \text{ W}$$

The ratio of the conduction heat rate to the net power output is

$$r = \frac{q}{P} = \frac{92.4 \text{ W}}{5 \times 10^6 \text{ W}} = 18.5 \times 10^{-6} \quad <$$

(b) The volume of the turbine is proportional to L^3 . Designating $L_a = 1 \text{ m}$, $d_a = 70 \text{ mm}$ and P_a as the shaft length, shaft diameter, and net power output, respectively, in part (a),

$$d = d_a \times (L/L_a); P = P_a \times (L/L_a)^3$$

and the ratio of the conduction heat rate to the net power output is

$$\begin{aligned} r &= \frac{q'' A_c}{P} = \frac{\frac{k(T_h - T_c)}{L} (\pi d^2 / 4)}{P} = \frac{\frac{k(T_h - T_c)}{L} (\pi (d_a L / L_a)^2 / 4)}{P_a (L/L_a)^3} = \frac{\frac{k(T_h - T_c) \pi}{4} d_a^2 L_a / P_a}{L^2} \\ &= \frac{\frac{40 \text{ W/m}\cdot\text{K} (1000 - 400)^\circ\text{C} \pi}{4} (70 \times 10^{-3} \text{ m})^2 \times 1 \text{ m} / 5 \times 10^6 \text{ W}}{L^2} = \frac{18.5 \times 10^{-6} \text{ m}^2}{L^2} \end{aligned}$$

Continued...

PROBLEM 1.8 (Cont.)

The ratio of the shaft conduction to net power is shown below. At $L = 0.005 \text{ m} = 5 \text{ mm}$, the shaft conduction to net power output ratio is 0.74. The concept of the very small turbine is not feasible since it will be unlikely that the large temperature difference between the compressor and turbine can be maintained. <

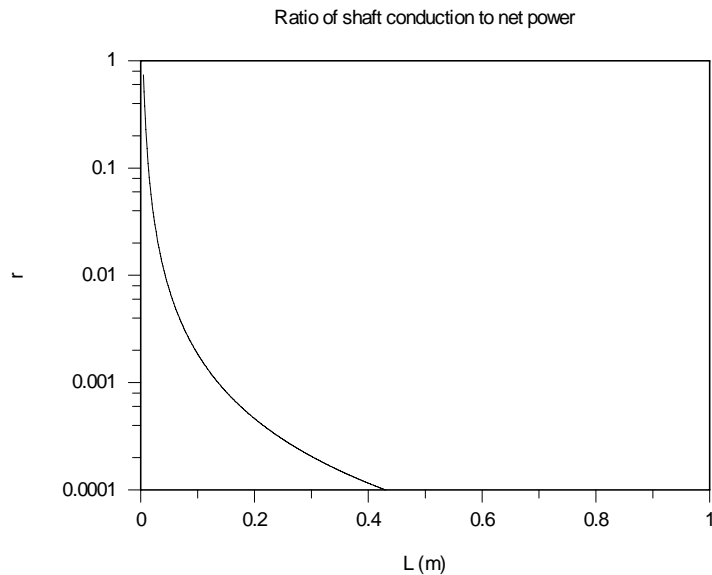

COMMENTS: (1) The thermodynamics analysis does not account for heat transfer effects and is therefore meaningful only when heat transfer can be safely ignored, as is the case for the shaft in part (a). (2) Successful miniaturization of thermal devices is often hindered by heat transfer effects that must be overcome with innovative design.

PROBLEM 1.9

KNOWN: Width, height, thickness and thermal conductivity of a single pane window and the air space of a double pane window. Representative winter surface temperatures of single pane and air space.

FIND: Heat loss through single and double pane windows.

SCHEMATIC:

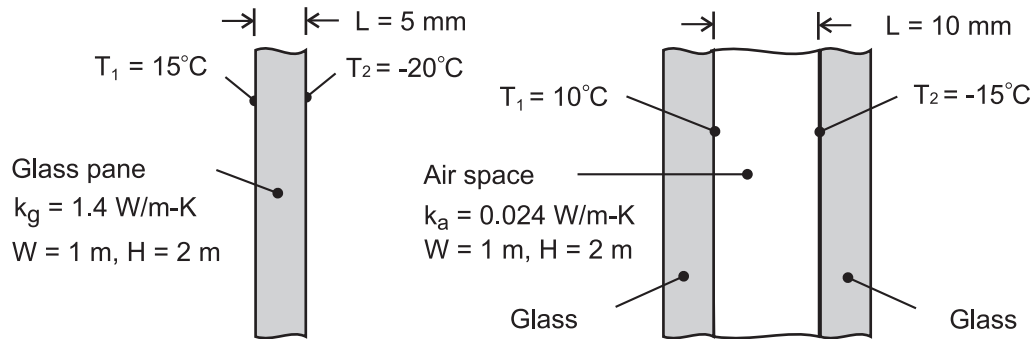

ASSUMPTIONS: (1) One-dimensional conduction through glass or air, (2) Steady-state conditions, (3) Enclosed air of double pane window is stagnant (negligible buoyancy induced motion).

ANALYSIS: From Fourier's law, the heat losses are

$$\text{Single Pane: } q_g = k_g A \frac{T_1 - T_2}{L} = 1.4 \text{ W/m}\cdot\text{K} \left(2 \text{ m}^2 \right) \frac{35^\circ\text{C}}{0.005 \text{ m}} = 19,600 \text{ W} <$$

$$\text{Double Pane: } q_a = k_a A \frac{T_1 - T_2}{L} = 0.024 \left(2 \text{ m}^2 \right) \frac{25^\circ\text{C}}{0.010 \text{ m}} = 120 \text{ W} <$$

COMMENTS: Losses associated with a single pane are unacceptable and would remain excessive, even if the thickness of the glass were doubled to match that of the air space. The principal advantage of the double pane construction resides with the low thermal conductivity of air (~ 60 times smaller than that of glass). For a fixed ambient outside air temperature, use of the double pane construction would also increase the surface temperature of the glass exposed to the room (inside) air.

PROBLEM 1.10

KNOWN: Dimensions of freezer compartment. Inner and outer surface temperatures.

FIND: Thickness of styrofoam insulation needed to maintain heat load below prescribed value.

SCHEMATIC:

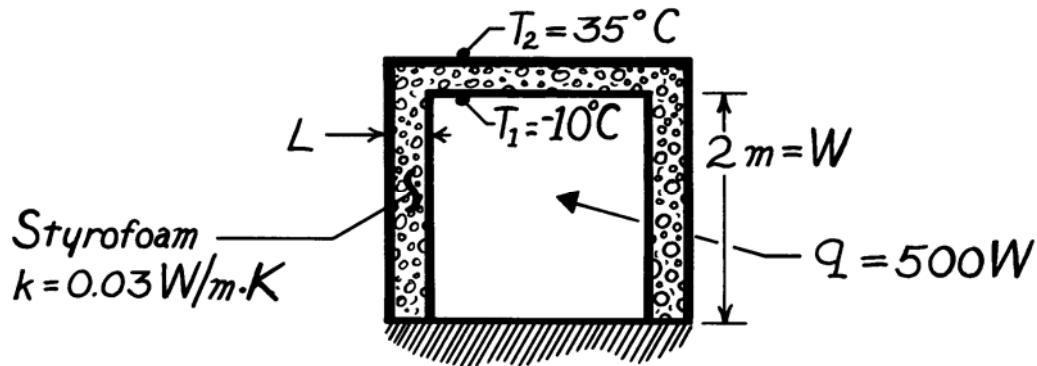

ASSUMPTIONS: (1) Perfectly insulated bottom, (2) One-dimensional conduction through 5 walls of area $A = 4m^2$, (3) Steady-state conditions, (4) Constant properties.

ANALYSIS: Using Fourier's law, Eq. 1.2, the heat rate is

$$q = q'' \cdot A = k \frac{\Delta T}{L} A_{\text{total}}$$

Solving for L and recognizing that $A_{\text{total}} = 5 \times W^2$, find

$$L = \frac{5 k \Delta T W^2}{q}$$

$$L = \frac{5 \times 0.03 \text{ W/m} \cdot \text{K} [35 - (-10)]^\circ \text{C} (4\text{m}^2)}{500 \text{ W}}$$

$$L = 0.054\text{m} = 54\text{mm.}$$

<

COMMENTS: The corners will cause local departures from one-dimensional conduction and a slightly larger heat loss.

PROBLEM 1.11

KNOWN: Heat flux at one face and air temperature and convection coefficient at other face of plane wall. Temperature of surface exposed to convection.

FIND: If steady-state conditions exist. If not, whether the temperature is increasing or decreasing.

SCHEMATIC:

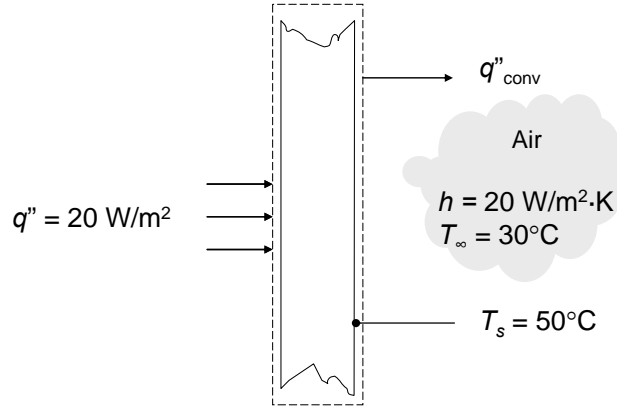

ASSUMPTIONS: (1) One-dimensional conduction, (2) No internal energy generation.

ANALYSIS: Conservation of energy for a control volume around the wall gives

$$\frac{dE_{st}}{dt} = \dot{E}_{in} - \dot{E}_{out} + \dot{E}_g$$

$$\begin{aligned} \frac{dE_{st}}{dt} &= q''_{in}A - hA(T_s - T_{\infty}) = [q''_{in} - h(T_s - T_{\infty})]A \\ &= [20 \text{ W/m}^2 - 20 \text{ W/m}^2 \cdot \text{K}(50^{\circ}\text{C} - 30^{\circ}\text{C})]A = -380 \text{ W/m}^2A \end{aligned}$$

Since $dE_{st}/dt \neq 0$, the system is not at steady-state. <

Since $dE_{st}/dt < 0$, the stored energy is decreasing, therefore the wall temperature is decreasing. <

COMMENTS: When the surface temperature of the face exposed to convection cools to 31°C , $q_{in} = q_{out}$ and $dE_{st}/dt = 0$ and the wall will have reached steady-state conditions.

PROBLEM 1.12

KNOWN: Dimensions and thermal conductivity of food/beverage container. Inner and outer surface temperatures.

FIND: Heat flux through container wall and total heat load.

SCHEMATIC:

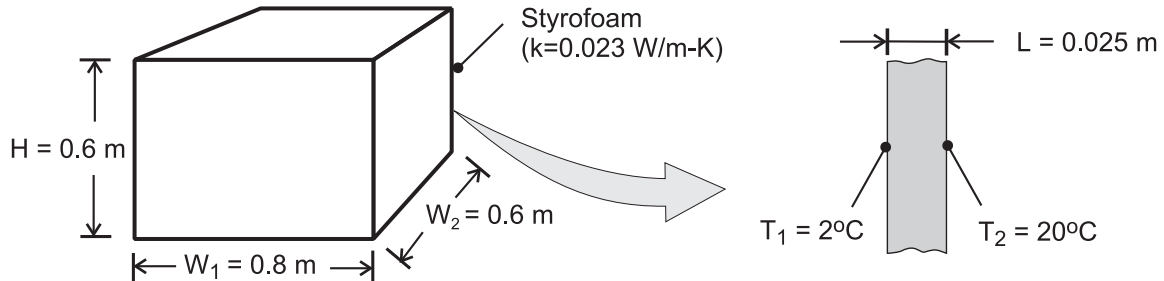

ASSUMPTIONS: (1) Steady-state conditions, (2) Negligible heat transfer through bottom wall, (3) Uniform surface temperatures and one-dimensional conduction through remaining walls.

ANALYSIS: From Fourier's law, Eq. 1.2, the heat flux is

$$q'' = k \frac{T_2 - T_1}{L} = \frac{0.023 \text{ W/m}\cdot\text{K} (20 - 2)^\circ\text{C}}{0.025 \text{ m}} = 16.6 \text{ W/m}^2 \quad <$$

Since the flux is uniform over each of the five walls through which heat is transferred, the heat load is

$$q = q'' \times A_{\text{total}} = q'' [H(2W_1 + 2W_2) + W_1 \times W_2]$$
$$q = 16.6 \text{ W/m}^2 [0.6\text{m}(1.6\text{m} + 1.2\text{m}) + (0.8\text{m} \times 0.6\text{m})] = 35.9 \text{ W} \quad <$$

COMMENTS: The corners and edges of the container create local departures from one-dimensional conduction, which increase the heat load. However, for $H, W_1, W_2 \gg L$, the effect is negligible.

PROBLEM 1.13

KNOWN: Masonry wall of known thermal conductivity has a heat rate which is 80% of that through a composite wall of prescribed thermal conductivity and thickness.

FIND: Thickness of masonry wall.

SCHEMATIC:

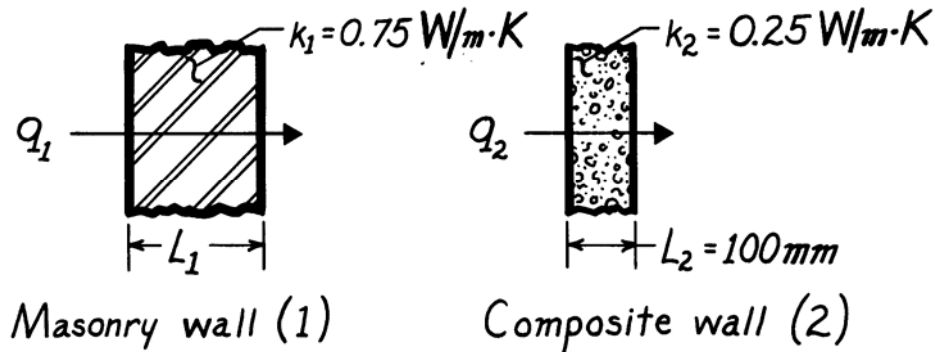

ASSUMPTIONS: (1) Both walls subjected to same surface temperatures, (2) One-dimensional conduction, (3) Steady-state conditions, (4) Constant properties.

ANALYSIS: For steady-state conditions, the conduction heat flux through a one-dimensional wall follows from Fourier's law, Eq. 1.2,

$$q'' = k \frac{\Delta T}{L}$$

where ΔT represents the difference in surface temperatures. Since ΔT is the same for both walls, it follows that

$$L_1 = L_2 \frac{k_1}{k_2} \cdot \frac{q_2''}{q_1''}$$

With the heat fluxes related as

$$q_1'' = 0.8 q_2''$$

$$L_1 = 100 \text{ mm} \frac{0.75 \text{ W/m}\cdot\text{K}}{0.25 \text{ W/m}\cdot\text{K}} \times \frac{1}{0.8} = 375 \text{ mm.} \quad <$$

COMMENTS: Not knowing the temperature difference across the walls, we cannot find the value of the heat rate.

PROBLEM 1.14

KNOWN: Expression for variable thermal conductivity of a wall. Constant heat flux. Temperature at $x = 0$.

FIND: Expression for temperature gradient and temperature distribution.

SCHEMATIC:

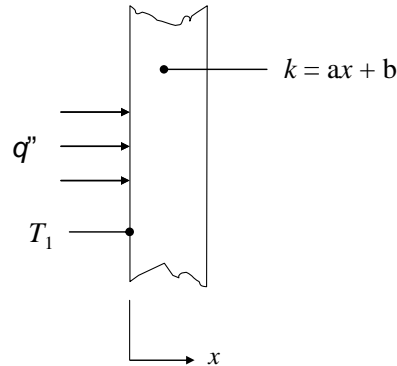

ASSUMPTIONS: (1) One-dimensional conduction.

ANALYSIS: The heat flux is given by Fourier's law, and is known to be constant, therefore

$$q_x'' = -k \frac{dT}{dx} = \text{constant}$$

Solving for the temperature gradient and substituting the expression for k yields

$$\frac{dT}{dx} = -\frac{q_x''}{k} = -\frac{q_x''}{ax + b} \quad <$$

This expression can be integrated to find the temperature distribution, as follows:

$$\int \frac{dT}{dx} dx = -\int \frac{q_x''}{ax + b} dx$$

Since $q_x'' = \text{constant}$, we can integrate the right hand side to find

$$T = -\frac{q_x''}{a} \ln(ax + b) + c$$

where c is a constant of integration. Applying the known condition that $T = T_1$ at $x = 0$, we can solve for c .

Continued...

PROBLEM 1.14 (Cont.)

$$\begin{aligned}T(x = 0) &= T_1 \\ -\frac{q_x''}{a} \ln b + c &= T_1 \\ c &= T_1 + \frac{q_x''}{a} \ln b\end{aligned}$$

Therefore, the temperature distribution is given by

$$\begin{aligned}T &= -\frac{q_x''}{a} \ln(ax + b) + T_1 + \frac{q_x''}{a} \ln b &< \\ &= T_1 + \frac{q_x''}{a} \ln \frac{b}{ax + b} &<\end{aligned}$$

COMMENTS: Temperature distributions are not linear in many situations, such as when the thermal conductivity varies spatially or is a function of temperature. Non-linear temperature distributions may also evolve if internal energy generation occurs or non-steady conditions exist.

PROBLEM 1.15

KNOWN: Thickness, diameter and inner surface temperature of bottom of pan used to boil water. Rate of heat transfer to the pan.

FIND: Outer surface temperature of pan for an aluminum and a copper bottom.

SCHEMATIC:

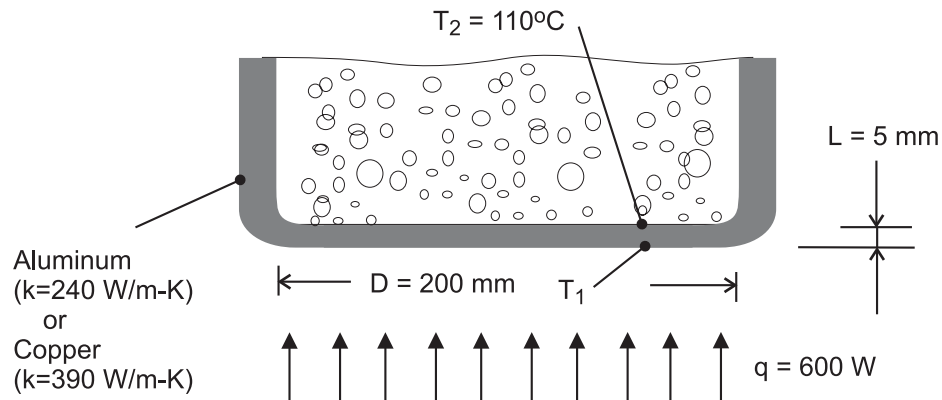

ASSUMPTIONS: (1) One-dimensional, steady-state conduction through bottom of pan.

ANALYSIS: From Fourier's law, the rate of heat transfer by conduction through the bottom of the pan is

$$q = kA \frac{T_1 - T_2}{L}$$

Hence,

$$T_1 = T_2 + \frac{qL}{kA}$$

where $A = \pi D^2 / 4 = \pi (0.2\text{ m})^2 / 4 = 0.0314\text{ m}^2$.

$$\text{Aluminum: } T_1 = 110^\circ\text{C} + \frac{600\text{ W}(0.005\text{ m})}{240\text{ W/m}\cdot\text{K}(0.0314\text{ m}^2)} = 110.40^\circ\text{C} \quad <$$

$$\text{Copper: } T_1 = 110^\circ\text{C} + \frac{600\text{ W}(0.005\text{ m})}{390\text{ W/m}\cdot\text{K}(0.0314\text{ m}^2)} = 110.24^\circ\text{C} \quad <$$

COMMENTS: Although the temperature drop across the bottom is slightly larger for aluminum (due to its smaller thermal conductivity), it is sufficiently small to be negligible for both materials. To a good approximation, the bottom may be considered *isothermal* at $T \approx 110^\circ\text{C}$, which is a desirable feature of pots and pans.

PROBLEM 1.16

KNOWN: Dimensions and thermal conductivity of a chip. Power dissipated on one surface.

FIND: Temperature drop across the chip.

SCHEMATIC:

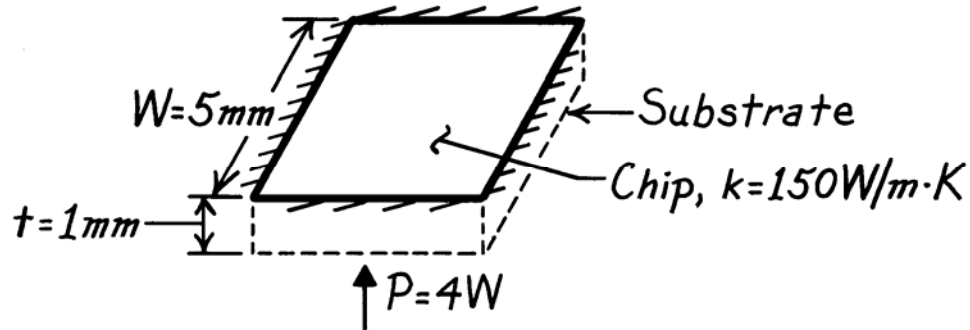

ASSUMPTIONS: (1) Steady-state conditions, (2) Constant properties, (3) Uniform heat dissipation, (4) Negligible heat loss from back and sides, (5) One-dimensional conduction in chip.

ANALYSIS: All of the electrical power dissipated at the back surface of the chip is transferred by conduction through the chip. Hence, from Fourier's law,

$$P = q = kA \frac{\Delta T}{t}$$

or

$$\Delta T = \frac{t \cdot P}{kW^2} = \frac{0.001\text{ m} \times 4\text{ W}}{150\text{ W/m}\cdot\text{K} (0.005\text{ m})^2}$$

$$\Delta T = 1.1^\circ\text{ C.}$$

<

COMMENTS: For fixed P , the temperature drop across the chip decreases with increasing k and W , as well as with decreasing t .